

# MB1247

Load Pin

## Content of Loadpin Datasheet

Page 1 ... General

Page 2 ... Mounting Situation

Page 3 ... Output Signal & Wiring

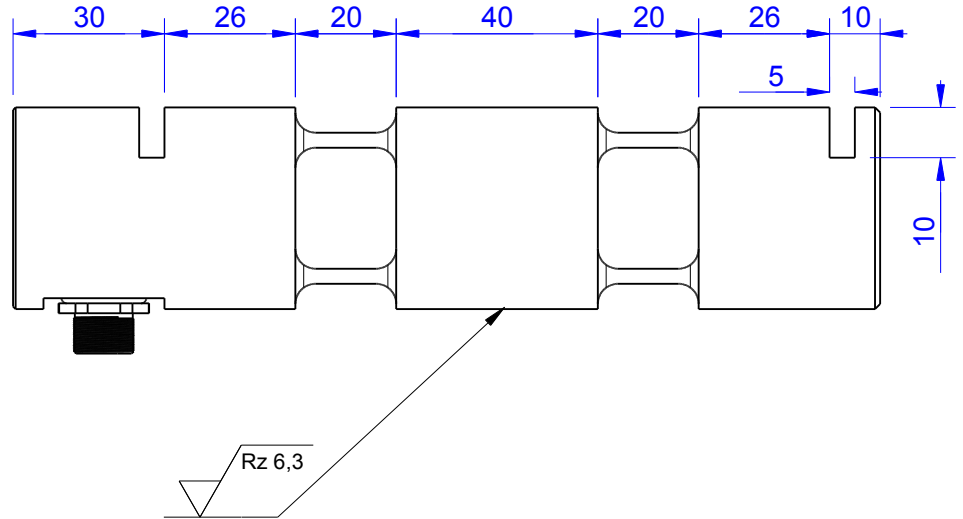
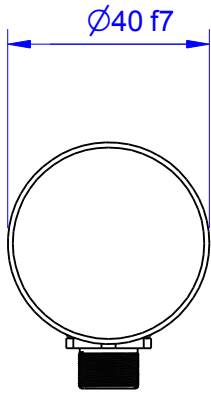

Order-number	Capacity (F.S.)	Uncertainty (k=2)	Review
MB1247-2-x-A	2 kN	±0,010kN	A
MB1247-5-x-A	5 kN	±0,025 kN	A
MB1247-10-x-A	10 kN	±0,050 kN	A
MB1247-20-x-A	20 kN	±0,100 kN	A
MB1247-40-x-A*	40 kN	±0,200 kN	A

\* above showed version  
The fixed dimensions don't change at the other capacity.

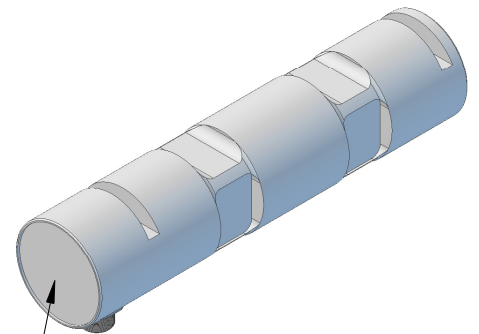

Marking:  
Loadpin: MBx  
Orderno.: MBx-xxx-x-x  
Serialno.: xxxxxxxx  
www.batarow.com  
Made in Germany

### Specifications:

Dimension / Material		
Material		Stainless Steel
Protection class		IP 66
Hardness (load area)	HRC	40..45
<b>Mechanical Data</b>		
Safe Load Limit	% of F.S.	150
Breaking Load	% of F.S.	300
<b>Precision</b>		
Nonlinearity	% of F.S.	±0,5
Nonrepeatability	% of F.S.	±0,25
Hysteresis	% of F.S.	±0,2
Temp. Shift Zero	% of F.S./K.	±0,05
Temp. Shift Span	% of F.S./K.	±0,05
<b>Temperature</b>		
Compensated Temp.	°C	-10...+65
Operating Temp.	°C	-20...+85

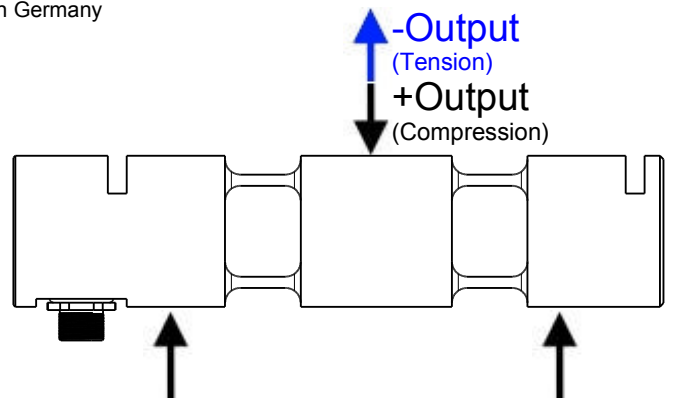

**Batarow**  
Made in Germany

Batarow Sensorik GmbH  
Pappelweg 16  
18276 Lüssow OT Karow

Mail: info@batarow.com  
Phone: +49 (0) 3843-855555  
Fax : +49 (0) 3843-218842

Internet:  
www.batarow.com

# Mounting Situation

MB1247 Review: A

Bore fit of mounting situation: H7

## Configuration

possible mounting situation / customer mounting could vary

(Please describe mounting situation with Vs, Ws, Xs, Ys and Zs for best possible calibration)

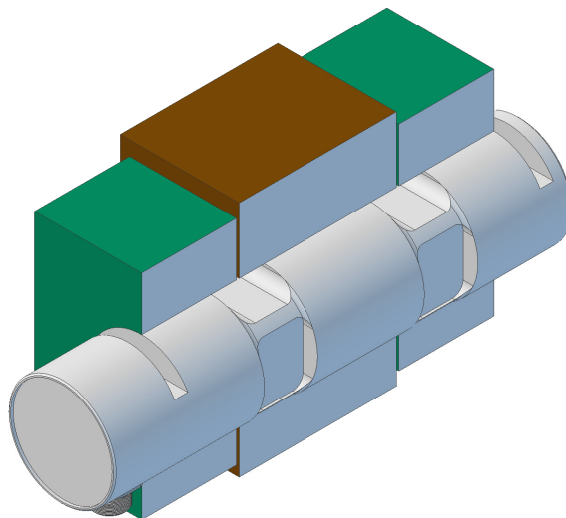
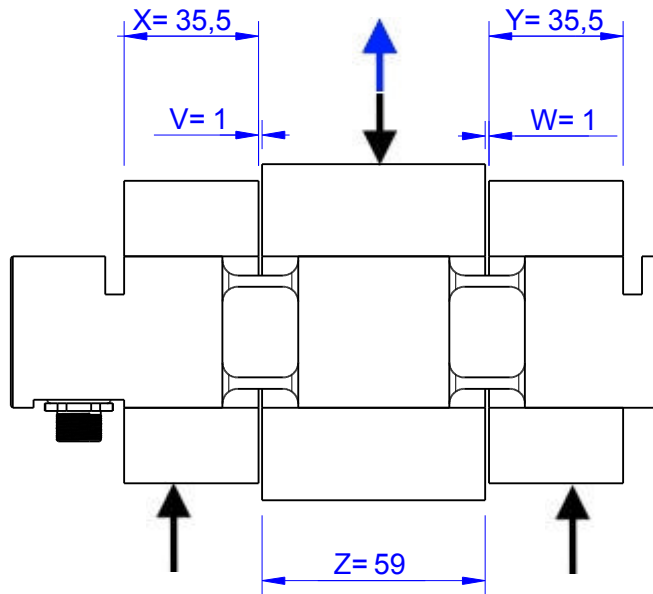

**Batarow**  
Made in Germany

Batarow Sensorik GmbH  
Pappelweg 16  
18276 Lüssow OT Karow

Mail: [info@batarow.com](mailto:info@batarow.com)  
Phone: +49 (0) 3843-855555  
Fax : +49 (0) 3843-218842

Internet:  
[www.batarow.com](http://www.batarow.com)

# Output Signal & Wiring

MB1247 Review: A

## Analog Output mV/V (S1)

Electrical Data		
Rated Output	mV/V@F.S.	1
Zero Balance	mV/V	±0,05
Exitation (Maximum)	Volt	10
Input Resistance	Ohm	450±100
Output Resistance	Ohm	352±2
Insulating Resistance	GOhm	>5

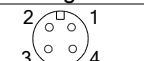
Wiringcode: WC58		Connectortype: M12 (male)			
	Exitation (+) Pin 1	Exitation (-) Pin 2	Bridge (+) Pin 3	Bridge (-) Pin 4	

Ordernumber Add-On:  
MBxxx-x-S1-x

## Analog Output 1V..10V (U1)\*

Electrical Data U1		
Output @ 0kN	V	1±0,2
Output @ F.S.	V	10±0,2
Supply Voltage	V	24±2
Current Consumption	mA	25 (@ 24V)
Bandwidth	kHz	0,3

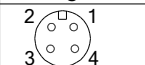
Wiringcode: WC36		Connectortype: M12 (male)		
	Supply (+) Pin 1	GND Pin 3	Output Pin 4	

Ordernumber Add-On:  
MBxxx-x-U1-x

## Analog Output 4..20mA (I1)\*

Electrical Data I1		
Output @ 0kN	mA	4±0,5
Output @ F.S.	mA	20±0,5
Supply Voltage	V	24±2
Current Consumption	mA	45 (@ 24V)
Bandwidth	kHz	0,3

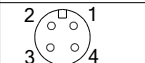
Wiringcode: WC36		Connectortype: M12 (male)		
	Supply (+) Pin 1	GND Pin 3	Output Pin 4	

Ordernumber Add-On:  
MBxxx-x-I1-x

## Analog & Switch Output 0V..10V (U42)\*

Electrical Data U42		
Output @ 0kN	V	5±0,2
Output @ ±F.S.	V	0/10±0,2
Supply Voltage	V	24±2
Current Consumption	mA	25 (@ 24V)
Bandwidth	kHz	2,2±0,2

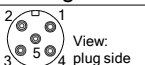
Wiringcode: WC46		Connectortype: M12 (male plug)				
	Supply (+) Pin 1	Output Pin 4	GND Pin 3	Tara Pin 2	Scale Pin 5	

Ordernumber Add-On:  
MBxxx-x-U42-x

Attention: Nipple orientation of connector is not fixed. In case of 90° connector - it is necessary to set by customer.

\*Attention: With this output configuration is no negative signal (Tension) possible. Please ask our engineering for 4..12..20mA; 1..5..9V or ±10V versions.

**Batarow**  
Made in Germany

Batarow Sensorik GmbH  
Pappelweg 16  
18276 Lüssow OT Karow

Mail: info@batarow.com  
Phone: +49 (0) 3843-855555  
Fax : +49 (0) 3843-218842

**Internet:**  
www.batarow.com