

# MB1180

X-Y-Axis Load Pin

## Content of Loadpin Datasheet

Page 1 ... General  
 Page 2 ... Mounting Situation  
 Page 3 ... Output Signal & Wiring

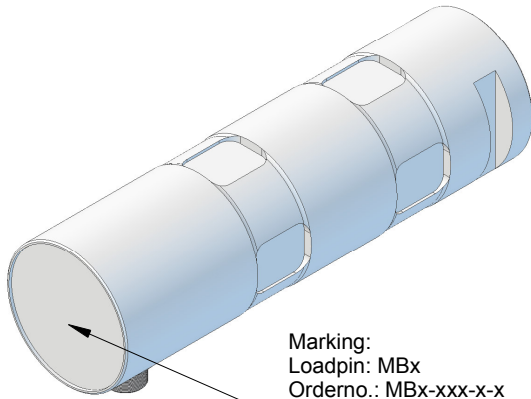
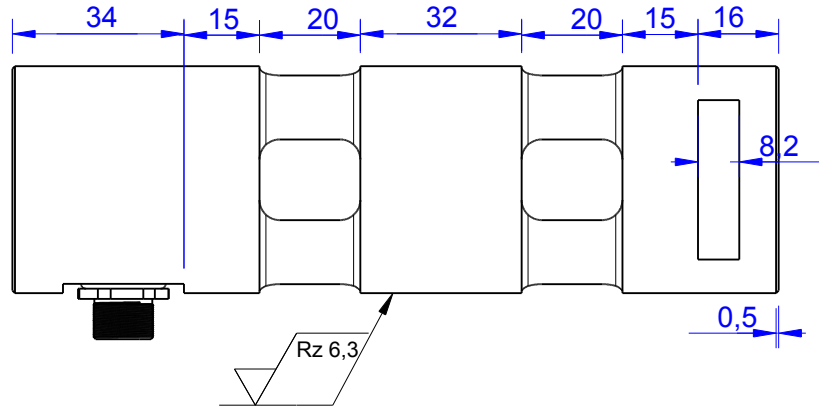
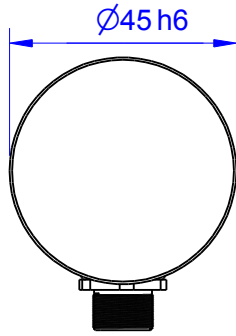

Marking:  
 Loadpin: MBx  
 Orderno.: MBx-xxx-x-x  
 Serialno.: xxxxxxxx  
 www.batarow.com  
 Made in Germany

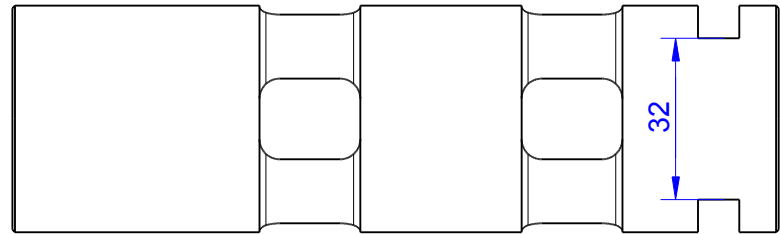

Order-number	Capacity (F.S.)	Uncertainty (k=2)	Review
MB1180-10-x-B	10 kN	±0,05kN	B
MB1180-20-x-B	20 kN	±0,10 kN	B
MB1180-65-x-B*	65 kN	±0,33 kN	B
MB1180-100-x-B	100 kN	±0,50 kN	B
MB1180-200-x-B	200 kN	±1,00 kN	B

\* above showed version  
 The fixed dimensions don't change at the other capacity.

### Specifications:

Dimension / Material		
Material		Stainless Steel
Protection class		IP 66
Hardness (load area)	HRC	40..45
<b>Mechanical Data</b>		
Safe Load Limit	% of F.S.	150
Breaking Load	% of F.S.	300
<b>Precision</b>		
Nonlinearity	% of F.S.	±0,5
Nonrepeatability	% of F.S.	±0,25
Hysteresis	% of F.S.	±0,2
Temp. Shift Zero	% of F.S./K.	±0,05
Temp. Shift Span	% of F.S./K.	±0,05
<b>Temperature</b>		
Compensated Temp.	°C	-10...+60
Operating Temp.	°C	-20...+70

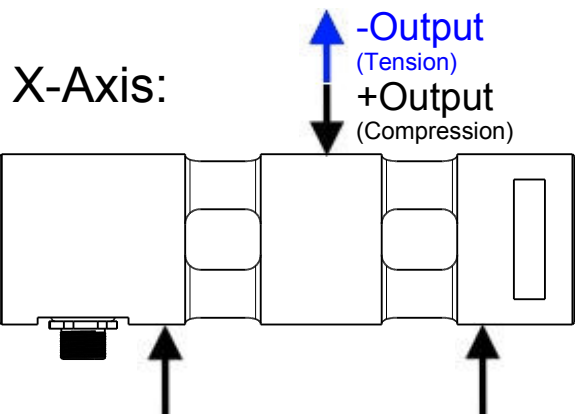
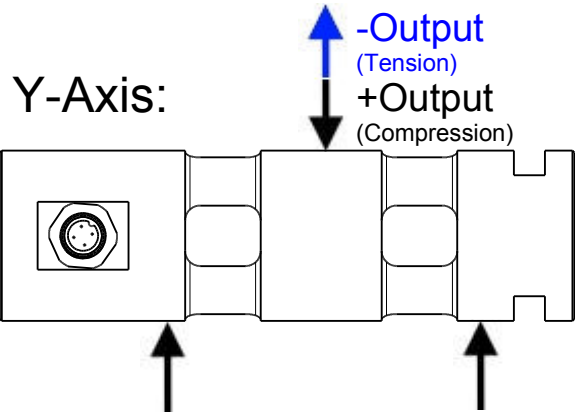

# Mounting Situation

MB1180 Review: B

Bore fit of mounting situation: H7

## Configuration

possible mounting situation / customer mounting could vary

(Please describe mounting situation with Vs, Ws, Xs, Ys and Zs for best possible calibration)

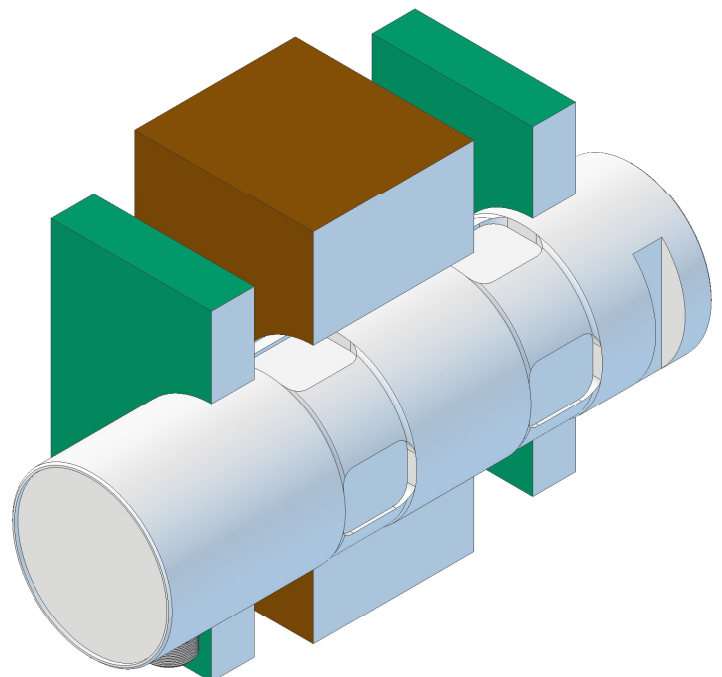
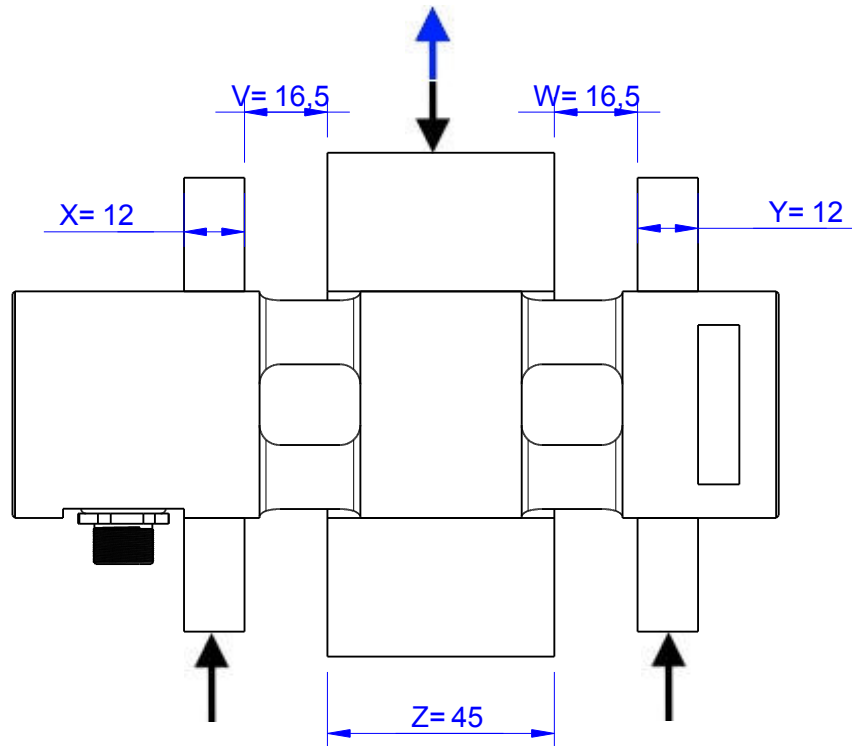

**Batarow**  
Made in Germany

Batarow Sensorik GmbH  
Pappelweg 16  
18276 Lüssow OT Karow

Mail: [info@batarow.com](mailto:info@batarow.com)  
Phone: +49 (0) 3843-855555  
Fax : +49 (0) 3843-218842

Internet:  
[www.batarow.com](http://www.batarow.com)

# Output Signal & Wiring

MB1180 Review: B

## Analog Output mV/V (S1)

Electrical Data		
Rated Output	mV/V@F.S.	1
Zero Balance	mV/V	±0,05
Excitation (Maximum)	Volt	10
Input Resistance	Ohm	450±100
Output Resistance	Ohm	352±2
Insulating Resistance	GOhm	>5

Wiringcode: WC56				
Cabeling: M12 Male Socket / Flanschdose (male)				
+Us (Fx)	Pin 2 / brown	+Us (Fy)	Pin 6 / pink	
-Us (Fx)	Pin 1 / white	-Us (Fy)	Pin 5 / grey	
+Ud (Fx)	Pin 3 / green	+Ud (Fy)	Pin 7 / blue	
-Ud (Fx)	Pin 4 / yellow	-Ud (Fy)	Pin 8 / red	

Ordernumber Add-On:  
MBxxx-x-S1-x

## Analog Output 1V..10V (U1)\*

Electrical Data U1		
Output @ 0kN	V	1±0,2
Output @ F.S.	V	10±0,2
Supply Voltage	V	24±2
Current Consumption	mA	25 (@ 24V)
Bandwidth	kHz	0,3

Wiringcode: WC48		Connectortype: M12 (male)		
	Supply (+)	GND	Output X	Output Y
	Pin 1	Pin 3	Pin 4	Pin 2

Ordernumber Add-On:  
MBxxx-x-U1-x

## Analog Output 4..20mA (I4)\*

Electrical Data I4		
Output @ -F.S.	mA	4±0,3
Output @ 0kN	mA	12±0,3
Output @ +F.S.	mA	20±0,3
Supply Voltage	V	12±1
Current Consumption	mA	45 (@ 12V)
Bandwidth	kHz	2,2±0,2

Wiringcode: WC48		Connectortype: M12 (male)		
	Supply (+)	GND	Output X	Output Y
	Pin 1	Pin 3	Pin 4	Pin 2

Ordernumber Add-On:  
MBxxx-x-I4-x

Attention: Nipple orientation of connector is not fixed. In case of 90° connector - it is necessary to set by customer.

\*Attention: With this output configuration is no negative signal (Tension) possible. Please ask our engineering for 4..12..20mA; 1..5..9V or ±10V versions.

**Batarow**  
Made in Germany

Batarow Sensorik GmbH  
Pappelweg 16  
18276 Lüssow OT Karow

Mail: info@batarow.com  
Phone: +49 (0) 3843-855555  
Fax : +49 (0) 3843-218842

**Internet:**  
www.batarow.com