

# MB1152

Load Pin

## Content of Loadpin Datasheet

Page 1 ... General

Page 2 ... Mounting Situation

Page 3 ... Output Signal & Wiring

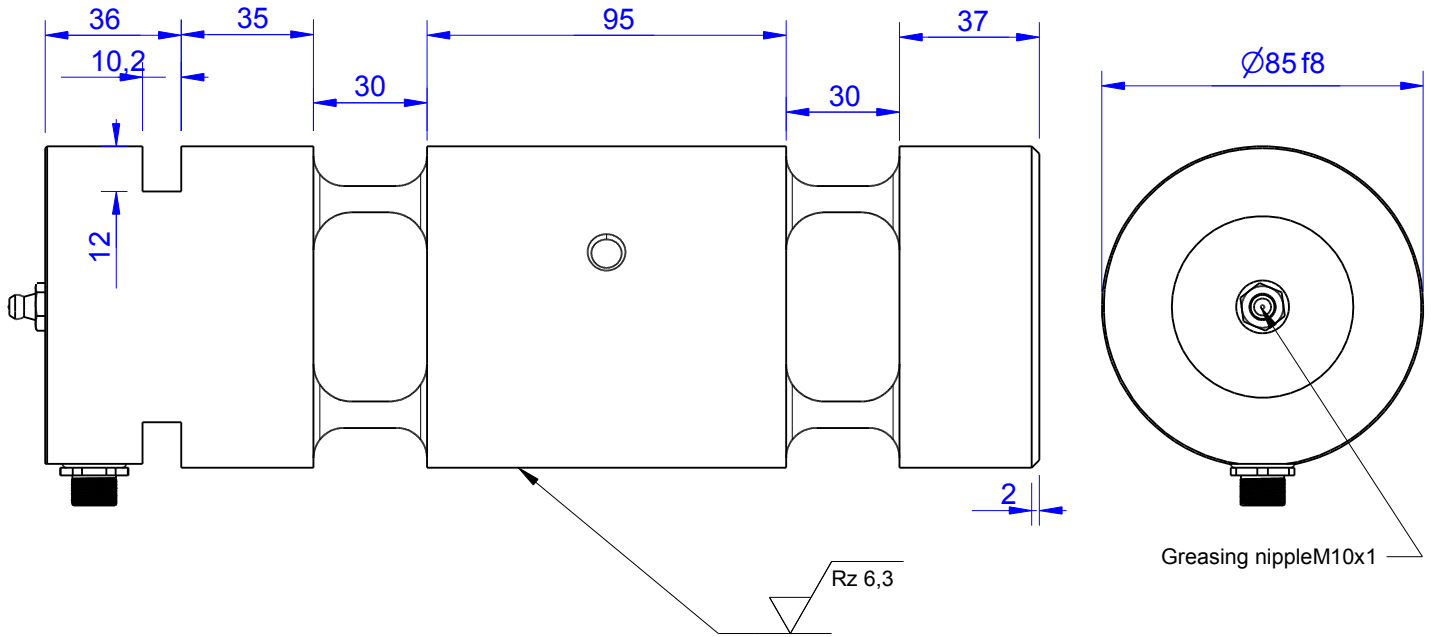

Order-number	Capacity (F.S.)	Uncertainty (k=2)	Review
MB1152-20-x-C	20 kN	±0,10kN	C
MB1152-50-x-C	50 kN	±0,25 kN	C
MB1152-150-x-C*	150 kN	±0,75 kN	C
MB1152-200-x-C	200 kN	±1,00 kN	C
MB1152-600-x-C	600 kN	±3,00 kN	C

\* above showed version

The fixed dimensions don't change at the other capacity.

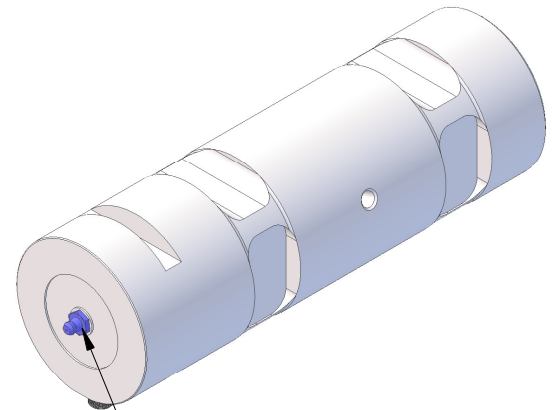

Marking:  
Loadpin: MBx  
Orderno.: MBx-xxx-x-x  
Serialno.: xxxxxxxx  
www.batarow.com  
Made in Germany

## Specifications:

Dimension / Material		
Material		Steel
Protection class		IP 66
Hardness (load area)	HRC	44..48
<b>Mechanical Data</b>		
Safe Load Limit	% of F.S.	150
Breaking Load	% of F.S.	300
<b>Precision</b>		
Nonlinearity	% of F.S.	±0,5
Nonrepeatability	% of F.S.	±0,25
Hysteresis	% of F.S.	±0,2
Temp. Shift Zero	% of F.S./K.	±0,05
Temp. Shift Span	% of F.S./K.	±0,05
<b>Temperature</b>		
Compensated Temp.	°C	-10...+60
Operating Temp.	°C	-20...+70

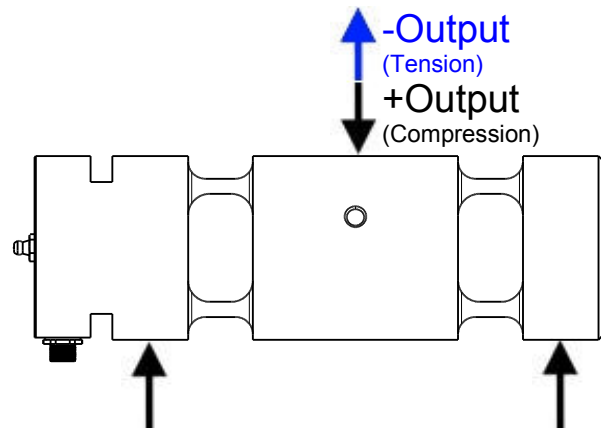

**Batarow**  
Made in Germany

Batarow Sensorik GmbH  
Pappelweg 16  
18276 Lüssow OT Karow

Mail: info@batarow.com  
Phone: +49 (0) 3843-855555  
Fax : +49 (0) 3843-218842

**Internet:**  
www.batarow.com

# Mounting Situation

MB1152 Review: C

Bore fit of mounting situation: H7

## Configuration

possible mounting situation / customer mounting could vary

(Please describe mounting situation with Vs, Ws, Xs, Ys and Zs for best possible calibration)

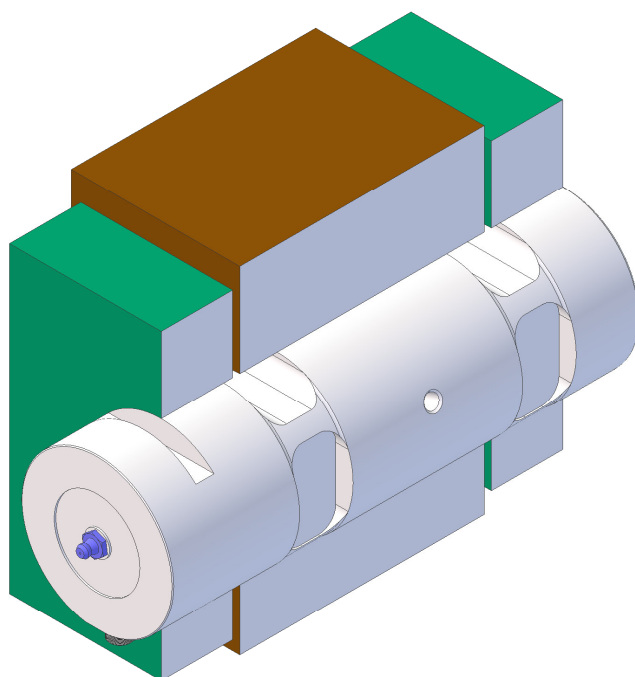
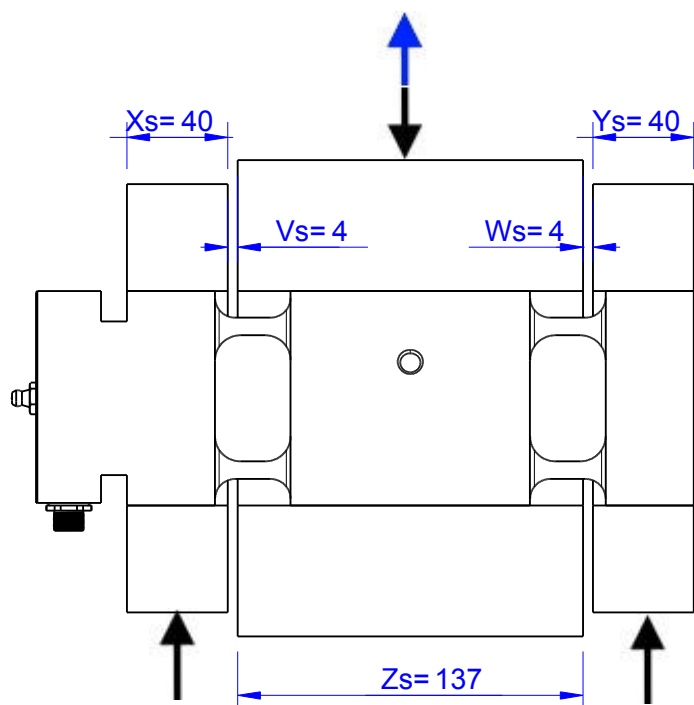

**Batarow**  
Made in Germany

Batarow Sensorik GmbH  
Pappelweg 16  
18276 Lüssow OT Karow

Mail: [info@batarow.com](mailto:info@batarow.com)  
Phone: +49 (0) 3843-855555  
Fax : +49 (0) 3843-218842

Internet:  
[www.batarow.com](http://www.batarow.com)

# Output Signal & Wiring

MB1152 Review: C

## Analog Output mV/V (S1)

Electrical Data		
Rated Output	mV/V@F.S.	1
Zero Balance	mV/V	±0,05
Exitation (Maximum)	Volt	10
Input Resistance	Ohm	450±100
Output Resistance	Ohm	352±2
Insulating Resistance	GOhm	>5

Wiringcode: WC58		Connectortype: M12 (male)			
	Exitation (+) Pin 1	Exitation (-) Pin 2	Bridge (+) Pin 3	Bridge (-) Pin 4	

Ordernumber Add-On:  
MBxxx-x-S1-x

## Analog Output 1V..10V (U1)\*

Electrical Data U1		
Output @ 0kN	V	1±0,2
Output @ F.S.	V	10±0,2
Supply Voltage	V	24±2
Current Consumption	mA	25 (@ 24V)
Bandwidth	kHz	2,2±0,2

Wiringcode: WC36		Connectortype: M12 (male)		
	Supply (+) Pin 1	GND Pin 3	Output Pin 4	

Ordernumber Add-On:  
MBxxx-x-U1-x

## Analog Output 4..20mA (I1)\*

Electrical Data I1		
Output @ 0kN	mA	4±0,5
Output @ F.S.	mA	20±0,5
Supply Voltage	V	24±2
Current Consumption	mA	45 (@ 24V)
Bandwidth	kHz	2,2±0,2

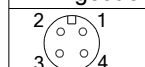
Wiringcode: WC36		Connectortype: M12 (male)		
	Supply (+) Pin 1	GND Pin 3	Output Pin 4	

Ordernumber Add-On:  
MBxxx-x-I1-x

## Analog & Switch Output 0V..10V (U20)\*

Electrical Data U20		
Output @ 0kN	V	0
Output @ F.S.	V	10
Supply Voltage	V	11..30
Current Consumption	mA	15 (@ 24V)
Bandwidth	Hz	105
Switching Output		Open Collector
max. Switching current	mA	100

Wiringcode: WC39			
Integrated Amplifier:GSV-15			
Cabeling: M12 Male Socket / Flanschdose (male)			
Supply(+)	Pin 1	Scale	Pin 5
Ground (-)	Pin 3	Threshold	Pin 6
Output	Pin 4	Output Ground	Pin 7
Tare	Pin 2		



Ordernumber Add-On:  
MBxxx-x-U20-x

## Analog & Switch Output 4..20mA (I20)\*

Electrical Data I20		
Output @ 0kN	mA	4
Output @ F.S.	mA	20
Supply Voltage	V	11..30
Current Consumption	mA	15 (@ 24V)
Bandwidth	Hz	105
Switching Output		Open Collector
max. Switching current	mA	100

Wiringcode: WC39			
Integrated Amplifier:GSV-15			
Cabeling: M12 Male Socket / Flanschdose (male)			
Supply(+)	Pin 1	Scale	Pin 5
Ground (-)	Pin 3	Threshold	Pin 6
Output	Pin 4	Output Ground	Pin 7
Tare	Pin 2		



Ordernumber Add-On:  
MBxxx-x-I20-x

Attention: Nipple orientation of connector is not fixed. In case of 90° connector - it is necessary to set by customer.

\*Attention: With this output configuration is no negative signal (Tension) possible. Please ask our engineering for 4..12..20mA; 1..5..9V or ±10V versions.

**Batarow**  
Made in Germany

Batarow Sensorik GmbH  
Pappelweg 16  
18276 Lüssow OT Karow

Mail: info@batarow.com  
Phone: +49 (0) 3843-855555  
Fax : +49 (0) 3843-218842

**Internet:**  
www.batarow.com